

RF2F 5000+ Foot Drops

Steven K Richey President, 4Cable TV Inc

8 September 2011

Easily and inexpensively serve customers beyond the end of your systems

RF2F allows you to transition back to fiber and use RFoG technology to serve customers that you normally could not serve.

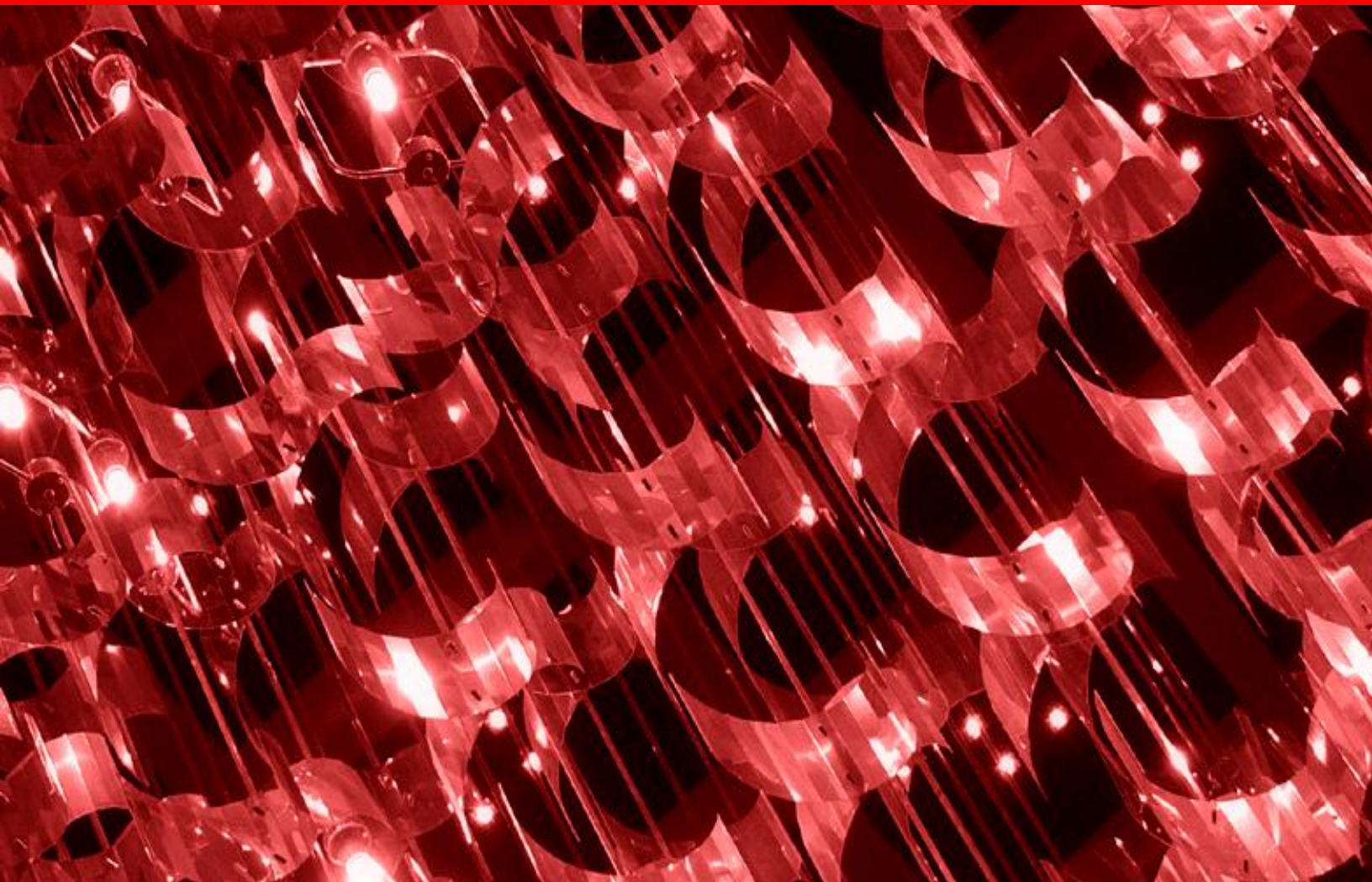

Disclaimer

The information contained in this document is the proprietary and exclusive property of 4Cable TV Inc. except as otherwise indicated. No part of this document, in whole or in part, may be reproduced, stored, transmitted, or used for design purposes without the prior written permission of 4Cable TV Inc.

The information contained in this document is subject to change without notice.

The material in this document is provided for informational purposes only. 4Cable TV Inc., specifically disclaims all warranties, express or limited, including, but not limited, to the implied warranties of merchantability and fitness for a particular purpose, except as provided for in a separate software license agreement.

Table of Contents

Executive Summary	4
Business Challenge.....	5
Solution Description	6
Solution Benefits	9
Target Market.....	11
Summary.....	12
More Information	12

Executive Summary

Overview

At the end of almost every feeder line there are a few more homes that could be fed with a system extension but the cost is prohibitive. It is estimated that there is an average of 2 potential customers within 2000 feet of every end of line. The RF2F comes with a single, dual, quad or 8 outputs to easily and inexpensively extend your system at an average cost of \$500.00 per customer.

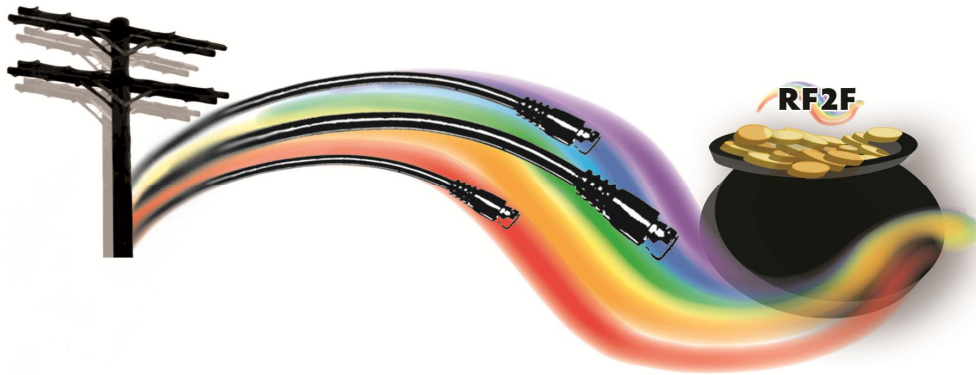

THERE IS A POT OF GOLD AT THE END OF YOUR LINES
Early Adopters Love it:

CATV Milestones

- 12 Channel Systems
- Solid State Amplifiers
- CARS Microwave
- 24 channel Systems
- Satellite delivered signals
- Fiber Optics
- Internet

These were all industry changing technologies and caused people in the industry to be excited. When presented with the RF2F concept operators are showing the same level of excitement.

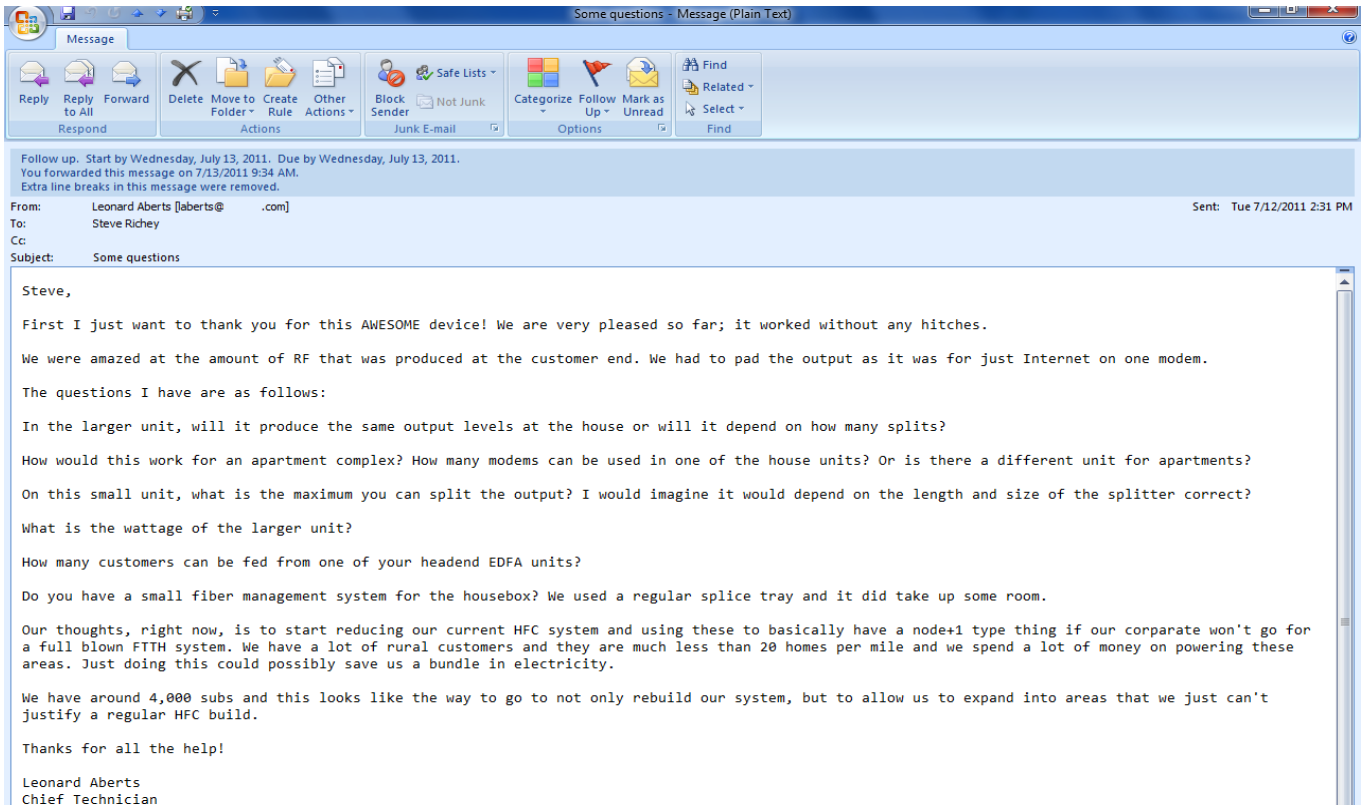

Business Challenge

At the end of almost every feeder line there are a few more homes that could be fed with a system extension but the cost is prohibitive. There are an average of 2 potential customers within 2000 feet of every end of line. Traditional methods of reaching these millions of potential customers are not cost effective

Challenge	Solution
Engineering costs	Drops do not normally require Engineering Fees
Line Extensions	NO line extensions-just long fiber drops
Pole attachment applications	Usually no application is required-just after the fact, drop notification

Cost Effective Expansion

Today MSOs are spending about \$3600 to purchase new subscribers, yet at the end of their existing feeders, there are millions of potential customers that can be served. By using RF2F technology a new customer can be acquired for a cost of under \$1,000 and in many cases for under \$500.00.

Systems, by simply making a paradigm shift in their strategy and using long fiber drops-can grow their customer base by 10-20%, without incurring large CAPX costs while flying under the radar screens of Wall Street.

Now there is a way to Serve those Millions of Potential Customers RF to Fiber (RF2F)

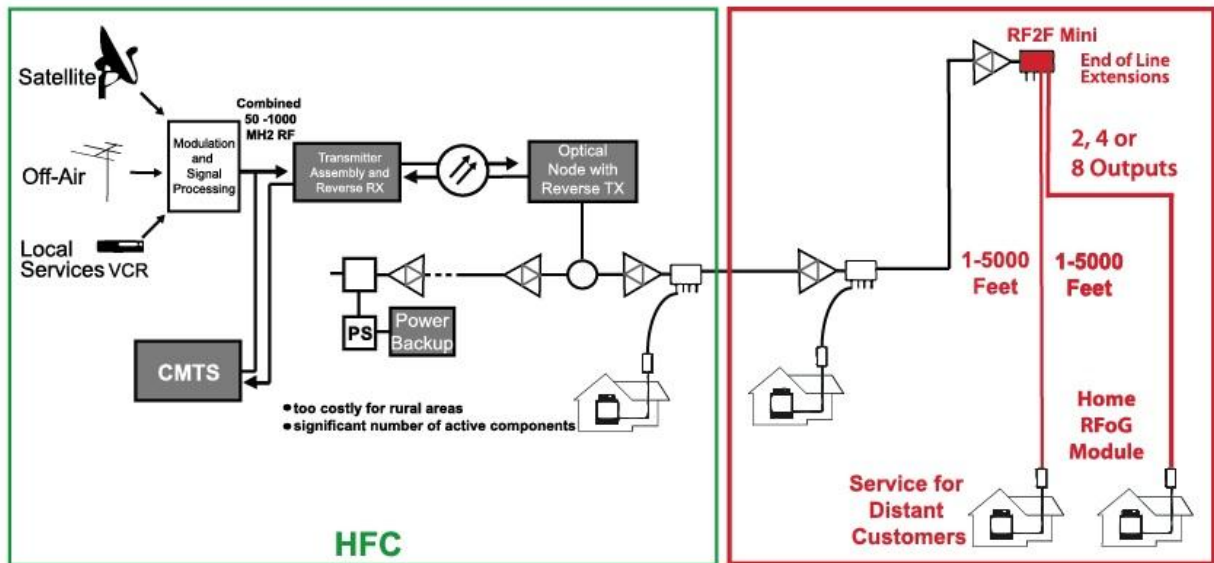

RF2F for System Extension

How it Works

Each RF2F unit includes a low power 1550 nm transmitter, a 1310 nm receiver, a WDM, a plug in changeable directional coupler and an AC power supply in a small die cast housing. On the side of the fiber fed

home you use a regular RFoG home unit and you can easily serve customers up to 5000 feet from you coax plant.

The RF2F unit is available in a single, dual quad or 8 output device each capable of serving one home.

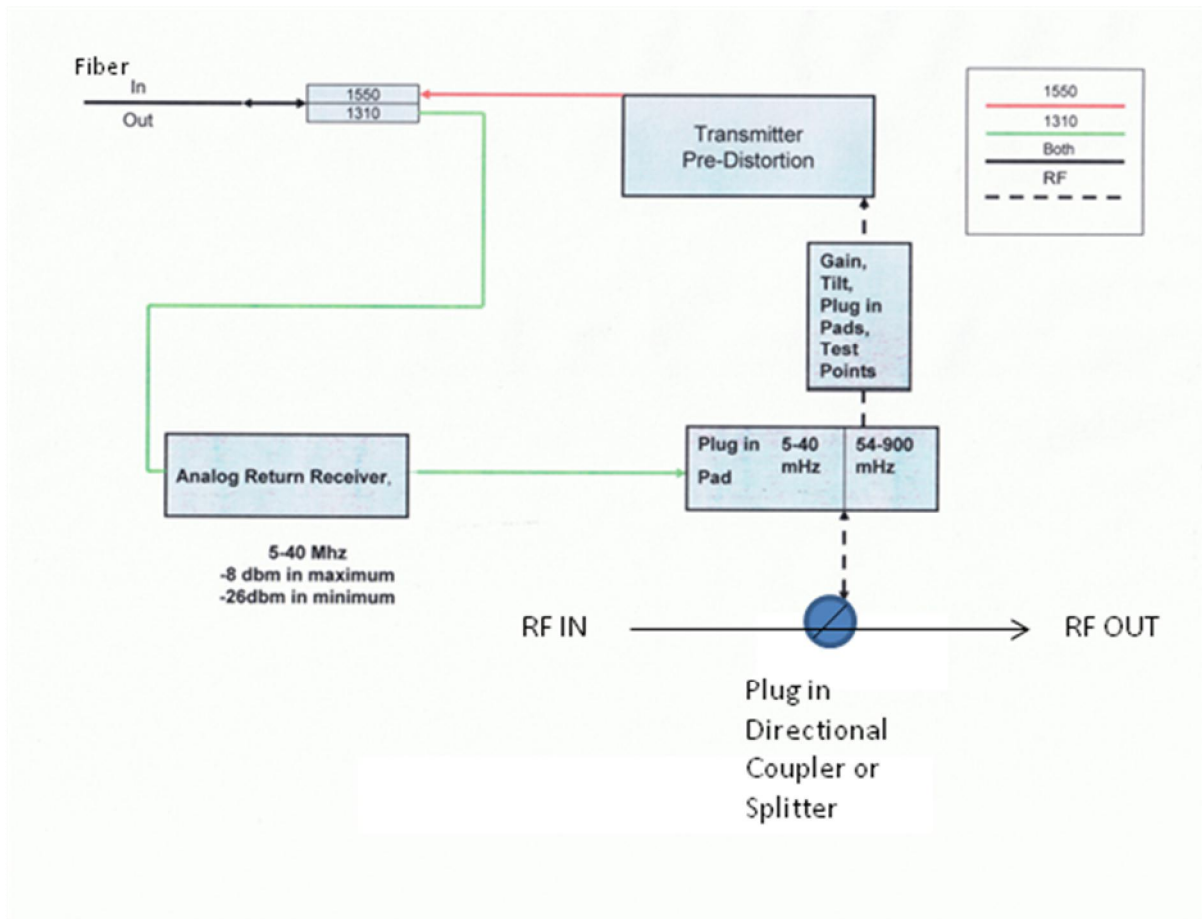

CARRIER TO NOISE PERFORMANCE

System C/N	System + RF2F C/N
46	44.81
47	45.54
48	46.24

RF2F Benefits and ROI

1. Single install cost;			
a. RF2F-mini-1way (2mW)	\$600.00		
b. R-ONU 1 each	\$135.00		
c. Fiber 6 count 1000 ft	\$240.00		
d. Misc Boxes connectors	\$ 50.00		
2. Total per customer	\$1025		
3. Dual install cost;			
a. RF2F-mini-2way (2mW)	\$690.00	\$690.00	
b. R-ONU 2 each	\$135.00	\$270.00	
c. Fiber 6 count 1000 ft	\$240.00	\$240.00	
d. Misc Boxes connectors	\$ 50.00	\$100.00	
4. Total per customer	\$650.00		
5. Quad install cost;			
a. RF2F-mini-4way (5mW)	\$995.00	\$995.00	
b. R-ONU 4 each	\$135.00	\$540.00	
c. Fiber 6 count 1000 ft	\$240.00	\$240.00	
d. Misc Boxes connectors	\$ 50.00	\$200.00	
6. Total per customer	\$494.00		
7. 8 Output install cost;			
a. RF2F-mini-4way (5mW)	\$1595.00	\$1595.00	
b. R-ONU 4 each	\$135.00	\$1040.00	
c. Fiber 8 count 1000 ft	\$260.00	\$260.00	
d. Misc Boxes connectors	\$ 50.00	\$400.00	
8. Total per customer	\$417.00		
9.			
10. Income;			
a. Installation Income	\$100.00		
b. 1 st Month cable and Internet Income	\$ 85.95		
c. Net after 1 st month Income	\$ 50.00		

11. ROI;

a. 8-Way install	5 months
b. Quad install	6 months
c. Dual Install	10 months
d. Single Install	17 months

Labor costs are not included as because of the following variables:

1. In house installation personal where the labor costs are already included in normal operation budgets;
2. Overhead installation by outside contractors;
3. Underground installation by outside contractors.

Technical Specifications

Parameter	2 mW	5mW
Output	3 dBm	7 dBm
CTB	70 dB	70 dB
CSO	65 dB	65 dB
Link CNR -1 dBm	51 dB	51 dB
Forward RF input	10 dBmv	10 dBmv
Return Insertion	1 to 3 dB	3 to 6 dB
Input RTL	14 dB	14 dB
Forward Flatness	±1 dB	±1 dB
Tilt*	1.5 dB	1.5 dB
Power	1.5 watts	1.75 watts

* Transmitter tilt, additional tilt will be added in the receiver

Target Market and Size of Market

The initial marketing thrust will be to the Independent operators. They have the ability to react quickly and utilize the RF2F product.

At the same time presentations to the major MSOs, will be made and qualifications and or trial installations will be initiated. Orders from these companies should begin about 1 years time .

We received information that Time Warner Cable has approximately 1,000,000 end of lines. Because of this we estimate that there are approximately 5,000,000 end of lines in the United States.

Deployment

The first test units have been in use since December of 2009. Feedback from the field since 2009 generated improvements in the RF2F Product line.

Summary

The RF2F family of products fill a unique void in the deployment of modern cable TV systems. Some of its advantages are:

- Potential 20% increase in subscriber count;
- With the market value of a subscriber between \$3,600 to \$4,500 - a high return on perceived value;
- Minimal or no engineering cost;
- 1 day installation;
- Pole attachments are classed as drops, no engineering fees;
- Only connect customers that are pre-signed, time contracts are very possible, short ROI almost 100% guaranteed;
- Perfect for hooking up business customers in business parks.

Contact Us

4Cable TV Inc
1256 Highway 501 Bus,
Conway, SC 29526
USA
Email: steve@4cable.tv
Website: www.RF2F.com
Tel: 843-347-4933
Fax: 843-347-4942

More Information

For the latest information about our product and services, please see the following resources:

Reference websites

<http://www.4cable.tv>

<http://www.rf2f.com>

<http://www.rfog.info>

Copyright ©2011 4Cable TV Inc. All Rights Reserved.

4Cable TV Inc. logos, and trademarks or registered trademarks of <your company> or its subsidiaries in the United States and other countries.
Copyright ©2007 <your company>. All Rights Reserved.

Other names and brands may be claimed as the property of others. Information regarding third party products is provided solely for educational purposes.
4Cable TV Inc. is not responsible for the performance or support of third party products and does not make any representations products.